



Gas Technical Guidelines and Safety Information for Property Developers

Electricity LV

Gas

Water
Telecomms

Highway

690

430

600

Contents

1. WELCOME

2. COMMUNICATIONS

3. SAFETY

4. DEFINITIONS

5. METER LOCATIONS

- Single Domestic Properties
- Flatted Properties
- Non-Domestic Properties
- Medium Pressure Supplies

6. METER HOUSINGS

- Meter Box Options
- Flatted Properties - Multi Meter Compartments
- Non-Domestic Properties - Meter Compartments
- Ventilation

7. INSTALLING GAS MAINS

- Excavations
- Road Crossing Ducts
- Backfill Materials

8. INSTALLING GAS SERVICES

- Below Ground
- Flatted Properties
 - External Risers
 - Internal Risers
 - Timber Frame

9. INSTALLING GAS METERS

- Domestic
- Non-Domestic
- Electrical Cross Bonding

10. CDM REGULATIONS



1. Welcome

Welcome from Manx Gas Ltd (MGL).

This brochure will provide you with information and guidance on the installation of gas mains, services and meters to new developments. At the end of the brochure you will find details relevant to the safety file required under the CDM Regulations.

Our Sales Team at Manx Gas will assist you with any enquiries you may have and will deal with technical enquiries through our Engineering Planning and Operations departments at our Head Office at Head Road Douglas.

Should you wish to contact us, the telephone number is 01624 644444.

2. Communications

When requesting work to be carried out on site, please contact the Distribution Department on 01624 644425.

Every effort will be made to meet the developer's requirements but we would ask for:

- **5 working days notice to deliver meter boxes**
- **5 working days notice to deliver service ducting**
- **15 working days notice to lay mains**
- **10 working days notice to lay services**
- **10 working days notice to lay services and fit meter**
- **40 working days notice for works in the Public Highway**
- **5 working days notice to supply and fit meters**

3. Safety

In accordance with the Institution of Gas Engineers guidance and Health & Safety Executive expectations, gas mains and services must be laid at the depths specified in sections 7 and 8 of this brochure.

The typical position of the gas main and other utilities apparatus in a footway is shown below (mm), this complies with N.J.U.G recommendations. Minimum depths of cover are also shown:

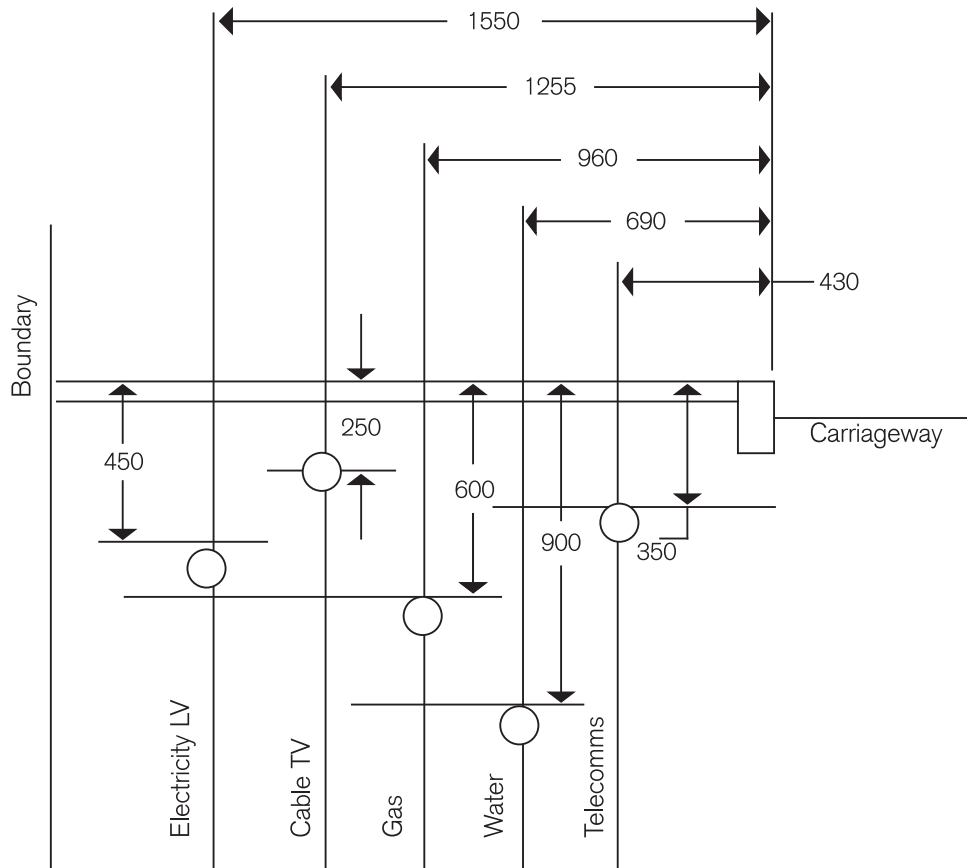

It is imperative that the gas mains are not damaged following installation and it is the responsibility of the developer to ensure that ALL contractors working on site are informed of the location of the gas mains. The mains and services drawing should be on site at all times and updated to clearly show the installation progress.

Damage to live gas mains must be reported immediately to the **Manx Gas Emergency number 0808 1624 444** who will arrange for Manx Gas Emergency personnel to attend site and undertake any repairs.

Any damage to un-gassed pipes, no matter how slight, must be reported immediately to Manx Gas.

For further information refer to HSE publication HSG47 "Avoiding danger from underground services" which gives detailed guidance on avoiding damage to gas mains and services, including information on detecting underground services and safe digging practices.

Free information is available from the **HSE Infoline on 0845 345 0055 or the HSE website www.hse.gov.uk**

4. Definitions

Gas Main	Underground pipe network for distributing gas throughout the property development
Gas Service	Underground pipe for conveying gas to premises from the gas main
Medium Pressure	The operating pressure in the Gas Main and Service when it exceeds 75mbar. In these circumstances additional safety features apply to the design of the meter installation. See section 5.
Meter Box	A purpose made glass reinforced polyester moulding to house domestic and small non-domestic meters
Meter Compartment	A room or cupboard specifically designed to house the meter installation
External Service Riser	A riser attached to the outside of a building or concealed in an external reveal
Internal Service Riser	A riser installed within the structure of a building
Ventilation	The movement of air and its replacement with fresh air due to the effects of wind and temperature gradients
Low Pressure	The usual operating pressure of the network, which does not exceed 75mbar
Regulator	A device whose function is to control pressure in a gas stream
Installation Pipe	The pipe work in a consumer's premises between the outlet of the meter and the appliances
N.J.U.G	National Joint Utilities Group

5. Meter Locations

General Requirements

All meters should be located in well-ventilated areas and be easily accessible to allow them to be read, maintained and isolated when necessary.

Meters must not be exposed to extreme temperatures, excessive humidity, vibration, corrosive substances, accidental damage, or ignition sources (e.g. switchgear).

It is the developer's responsibility to identify and show the required meter positions on the site plans.

Single Domestic Properties

Ideally meters should be located in an approved built-in or semi-concealed meter box, on the wall closest to the gas main.

Meters can be installed in garages or inside the building. The service entry will be above the damp proof course using an above ground entry tee and will continue in steel pipe terminating at the meter control valve.

Where a meter is to be located inside the building then it must be located in a ventilated cupboard, as close as practicable to an external, above ground service entry point.

Flatted Properties

Early consultation with Manx Gas should take place to agree meter locations to flatted properties.

The preferred location for meters supplying flatted properties is in standard meter boxes or a bank of meters in a purpose built compartment external to the building.

When meters cannot be located externally, then the preferred location is inside individual flats in a ventilated cupboard, as close as possible to an external wall to allow for a service entry via an external riser. When the proposed location is inside individual flats, but in an area that is the sole means of escape i.e. the entrance hall, the meter must be enclosed in a box, cupboard or compartment which will be at least 30 minutes fire resistant to BS 476 and which has self closing doors.

In situations where meters cannot be located inside individual flats, then a bank of meters on each floor level can be considered. However, the meter compartment is not permitted in an area that is the common sole means of escape e.g. common hallway.

If the building is of timber frame construction, then an internal riser is required, refer to section 8 for more detail.

Non-Domestic Properties

The preferred location is external to the building and as close as possible to the gas main.

When the meter has to be inside the building it should be located adjacent to an outside wall, with adequate ventilation and protected against accidental damage but not in close proximity to electrical switchgear, heating or process equipment.

If an internal meter is required for properties with 2 or more floors, it should not be sited on or under the stairway or in any other part of the premises which forms the sole means of escape in case of fire.

The meter should not be located in the immediate vicinity of hazardous installations e.g. fuel, paint or chemical stores.

Medium Pressure Supplies

Meters supplied from a medium pressure service must be housed externally to the building in a semi-concealed meter box or purpose built compartment.

The location of the meter box or compartment must be a minimum distance of 180mm from any window, air brick or other opening and minimum 330mm from any electrical equipment.

The proposed location for the meter and regulator installation and the design of any purpose built compartment must be agreed with Manx Gas at the initial design stage.

6. Meter Housings

Meter Box Options

General Requirements

The fitting of meter boxes and the installation pipe is the responsibility of the developer and must comply with the current version of the Gas Safety (Installation and Use) Regulations.

Each meter box is supplied with a key that must be passed onto the householder.

A damaged meter box is in contravention of the regulations and must not be installed. If a box is damaged after being installed, then it must be replaced, before the gas service and meter are connected.

Meter boxes should not bridge a damp proof course.

Built-In Box

This type of meter box cannot be used for medium pressure gas supplies.

The base of the box should be located between 500mm and 1000mm above the finished ground level.

The box must be installed and secured using cement or adhesive filler. It **must not** be secured using screws or nails as this could allow any leaking gas to enter the cavity.

The outlet spigot must fully bridge the cavity.

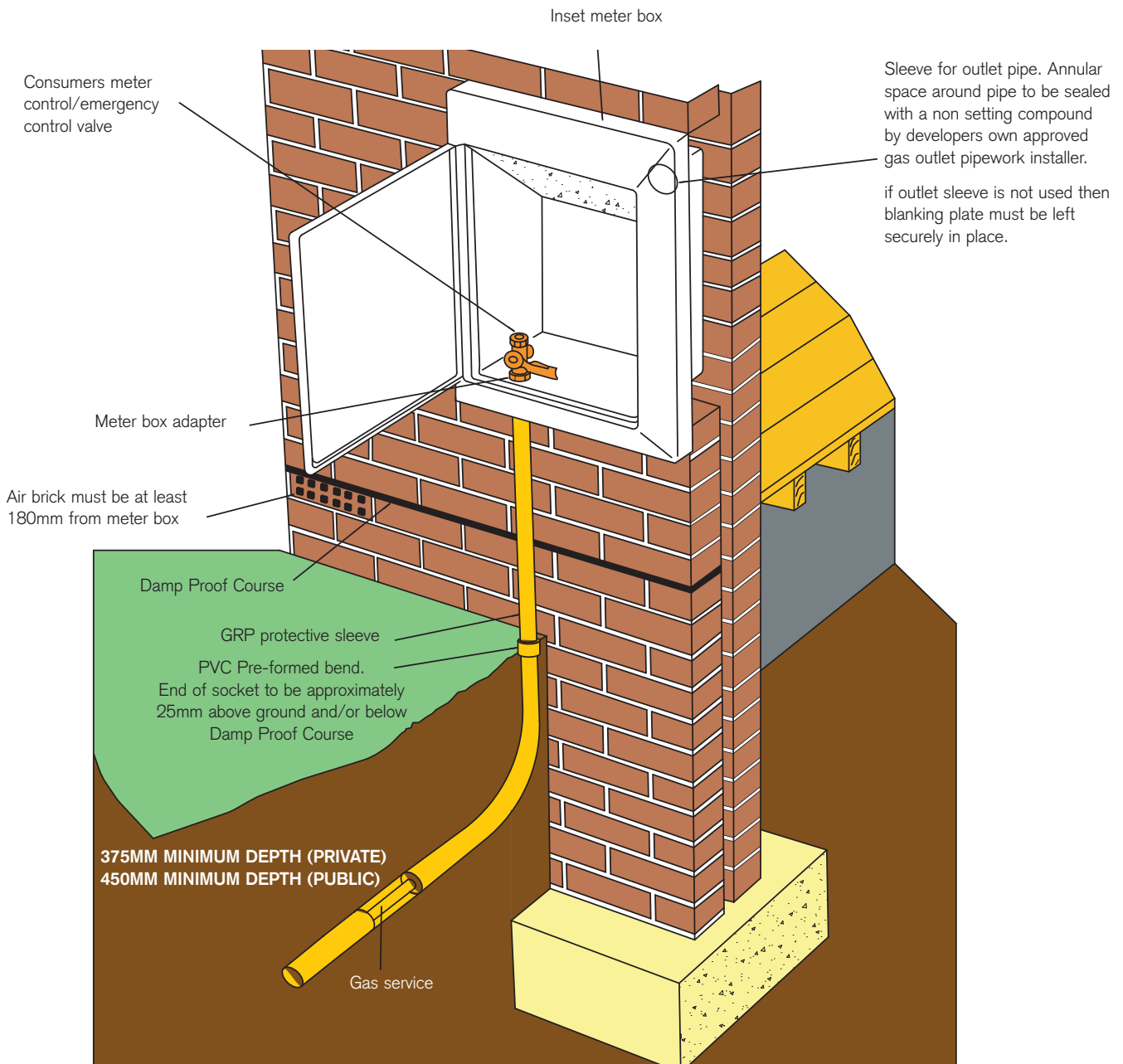

Semi-Concealed Box

The box is installed at ground level, buried not deeper than the indicated ground level on the box.

To avoid any restriction of air flow, it must not be sited in front of an air brick.

It must be secured to the wall using the spacers supplied with the meter box, wall plugs and screws.

The lid should be installed at the same time as fixing the box.

The installation pipe must be connected to the outlet adaptor fixed to the right hand side of the box (when viewed from the front). The pipe entering the building must pass through the wall via a continuous sleeve that must be sealed with non-setting mastic.

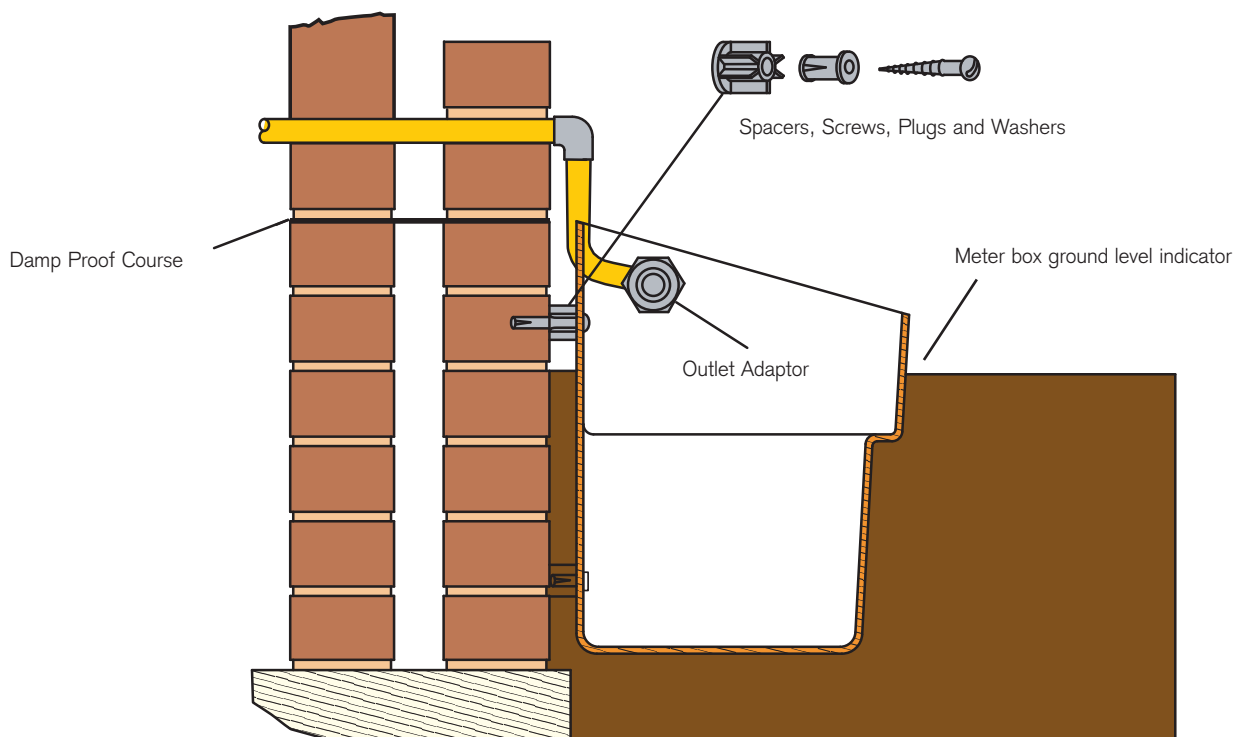

Flatted Properties – Multi-meter Compartments

External Compartment

A purpose built compartment may be located away from the building or set into the building structure. If set into the structure of the building the compartment must be completely sealed with the exception of an external access door and suitable ventilation to outside.

The free area of ventilation required, is a minimum of 2% or 3% of the floor area depending on the construction of the compartment. This can be in the form of a fully louvered door or vents evenly distributed at high and low levels. For more detail refer to the Ventilation section on page 9.

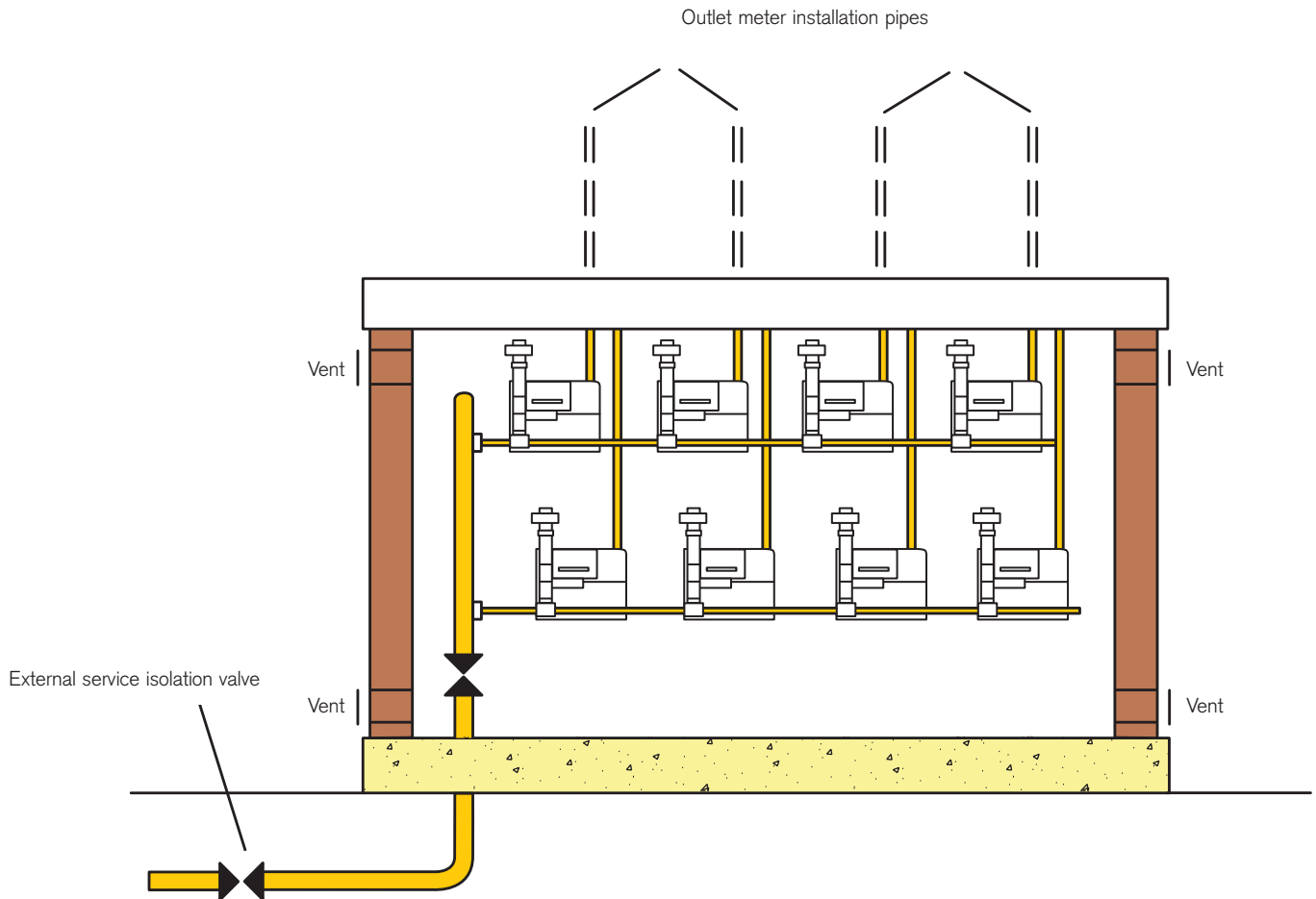

Internal Compartment

The compartment and access doors, must meet the structural and fire resistant requirements applicable to the building.

Solid access doors must be self-closing and non-lockable.

The ventilation to the outside atmosphere must be provided through suitably sized and constructed ducts, provided at high and low level. Ducts should be protected and constructed to prevent fire damage.

Refer to BS 8313 for duct sizing and further detail.

Non-domestic Properties – Meter Compartment

The walls of a purpose built compartment must be of solid construction without a cavity and must not include openings other than those required for access, ventilation, pipe work or other ancillary services.

The compartment should not be used for purposes other than regulating and metering the gas supply.

The total effective ventilation area of the compartment must be at least 2% of the floor area distributed equally at high and low levels over two or more walls. If ventilation is only available on one wall e.g. through louvered doors, it must be at least 3% of the floor area.

Refer to the Ventilation section below.

Refer to the Ventilation section below.

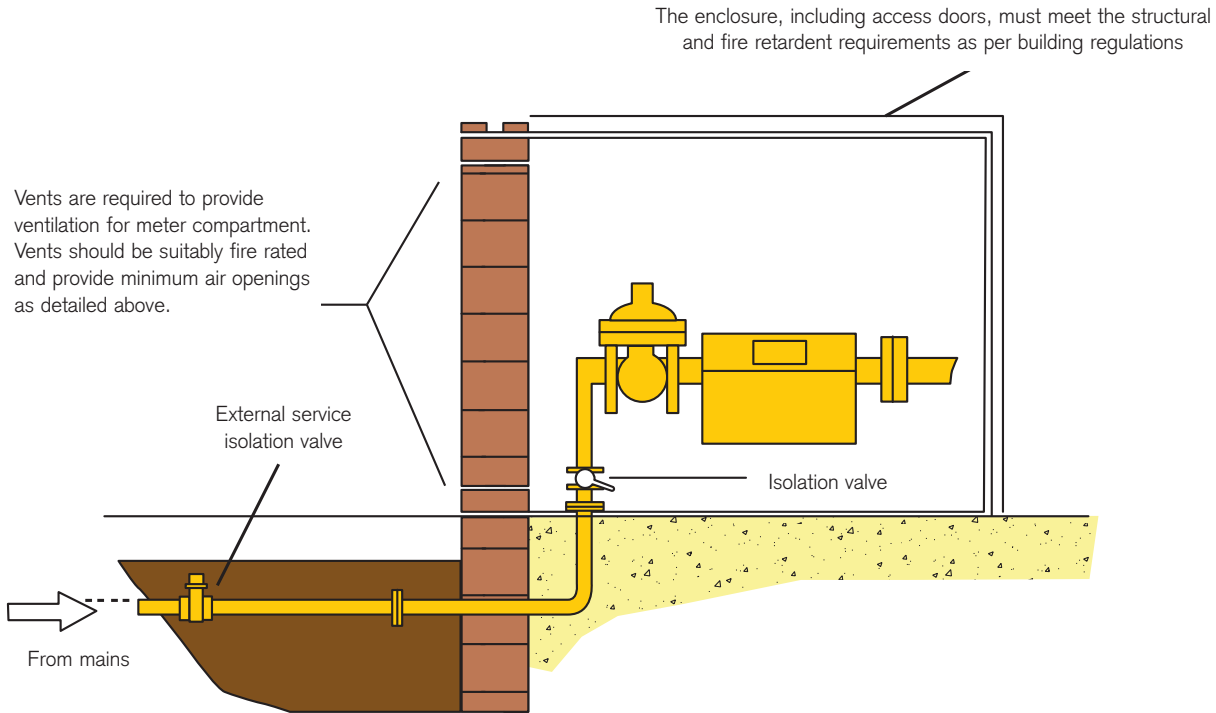

Meter Compartment Ventilation

Number of external walls	Minimum area of free of ventilation required as a percentage of the compartment floor area	Type of natural ventilation required to the outside	Position of low level vents	Position of high level vents
1	3%	Louvered door or high and low level ventilators	150mm above the floor	As close as possible below, but no more than 10% of the total compartment height below, the roof or ceiling level
2	2%	High and low level ventilators	150mm above the floor	
3	2%	High and low level ventilators	150mm above the floor	
4	2%	High and low level ventilators	150mm above the floor	

7. Installing Gas Mains

It is essential that the developer agrees a programme of construction which will enable Manx Gas to co-ordinate main laying activities, within our set timescales.

A site visit will be arranged at the start of your development. At any stage of construction you can contact a manx Gas Engineer for advice and guidance.

Timescales are particularly important when off site mains have to be laid and connected to the upstream Gas network and approval is required from the Street Authority to work in the public highway.

The developer is responsible for all excavations, duct laying and backfill work on site, unless otherwise requested at the quotation stage.

On request, Manx Gas will normally arrange for the on-site mains to be laid by within 15 working days, in trenches and/or ducts provided by the developer.

If there are any alterations to the agreed site layout, which may affect the route of the gas main, then Manx Gas must be advised immediately.

Excavations

The minimum depth of cover for mains should be 600mm in footways and 750mm in roadways/verges from the finished ground level.

The trench should be approximately the pipe diameter plus 300mm wide and minimum cover plus the pipe diameter deep.

The bottom of the trench should be trimmed to enable the main to be bedded evenly and consistently throughout the trench, at the correct cover. Sharp stones should be excluded from the base of the trench. Where the base of the trench is unsuitable e.g. rocks and stones, the trench should be excavated a further 75mm and a bed of suitable fine material laid and compacted.

No other utility should be installed over, below, or within 250mm to the side of the gas main.

Road Crossing Ducts

The laying of mains across roads can be in an open trench provided by the developer, but normally they are laid in rigid plastic ducting supplied and installed by the developer.

Corrugated ducting must not be used for road crossings.

The diameter of duct required for each size of main is shown below:

Diameter of main	Internal diameter of duct
63 mm	100 mm
90 mm	150 mm
125 mm	200 mm
180 mm and 250 mm	300 mm
315 mm	400 mm

Backfill Materials

The developer must ensure that the installed gas main is surrounded by sand or other suitable soft material to a depth of 150mm above the main as soon as possible to avoid damage.

Backfill and sub-base materials must be free from any organic, perishable or hazardous material.

A “gas pipe” marker tape, supplied by the Manx Gas, must be incorporated within the backfill for all mains and road crossing ducts and be positioned 250mm above the main or duct as shown below.

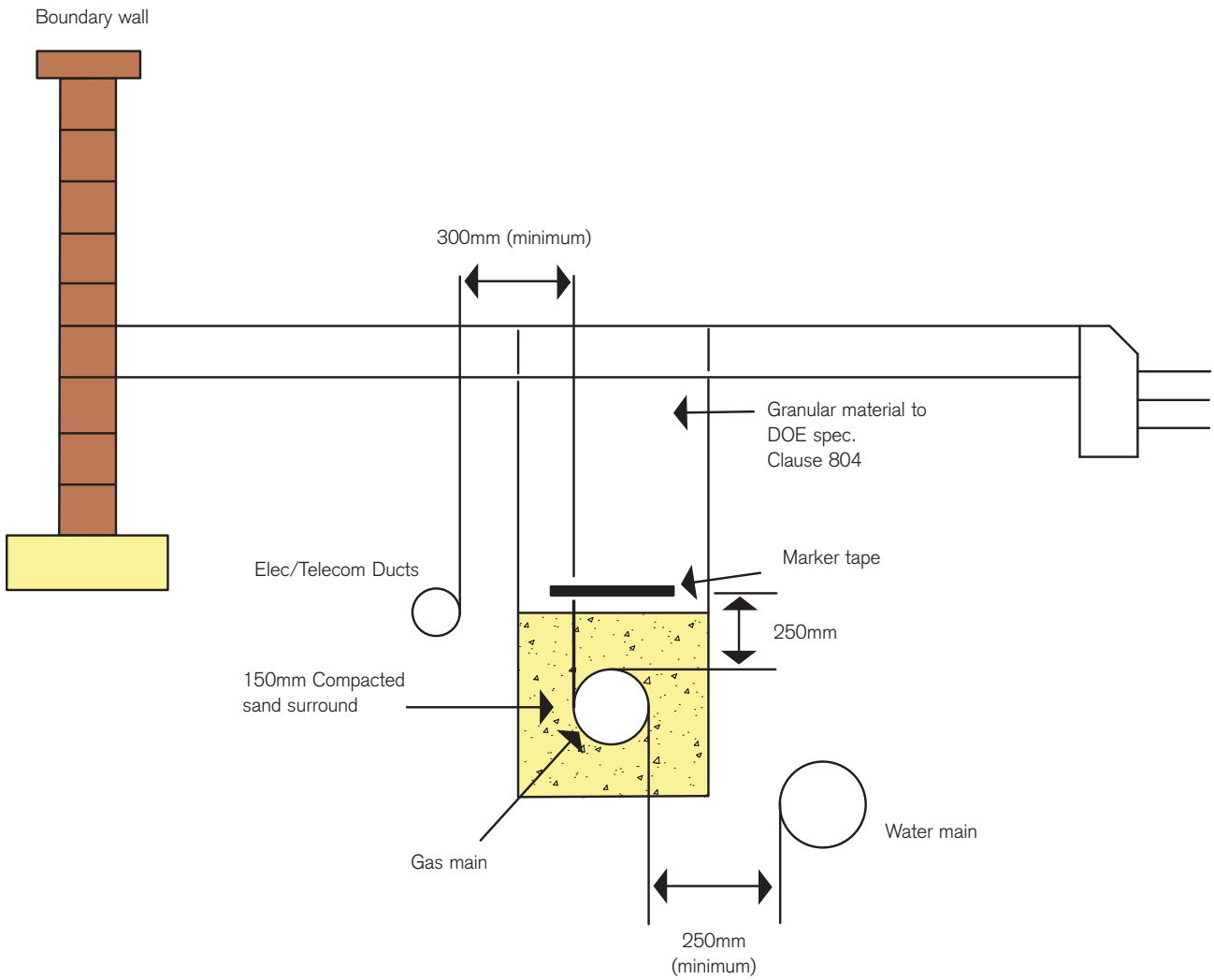

8. Installing Gas Services

The developer is required to undertake all excavation works on-site to enable the service pipe or ducting to be laid, allowing the connection to the main and the service termination at the building to be completed.

The gas service shall be laid in a straight line and as shown on the agreed network drawings. Any deviations must be agreed with Manx Gas, prior to laying the services

Below Ground

Service pipes up to 32mm diameter and/or ducting will be provided by Manx Gas and can be laid in a suitable pre-excavated trench by the developer or Manx Gas.

The ends of the pipe or duct must be capped or plugged at all times to prevent ingress of water or debris.

Services over 32mm diameter, shall be laid by Manx Gas in trenches provided by the developer.

Gas services must be laid with a minimum depth of cover of 375mm (private) and 450mm (public) from the finished ground level. Services over 63mm diameter must be laid to gas mains depths as specified in section 7.

**IF THERE IS INSUFFICIENT COVER THE SERVICE WILL NOT BE COMPLETED
AND THE DEVELOPER WILL BE NOTIFIED**

A 700mm square excavation is required at the gas main and below the meter box or service entry position to enable the service pipe to be connected to the gas main and terminated at the meter location.

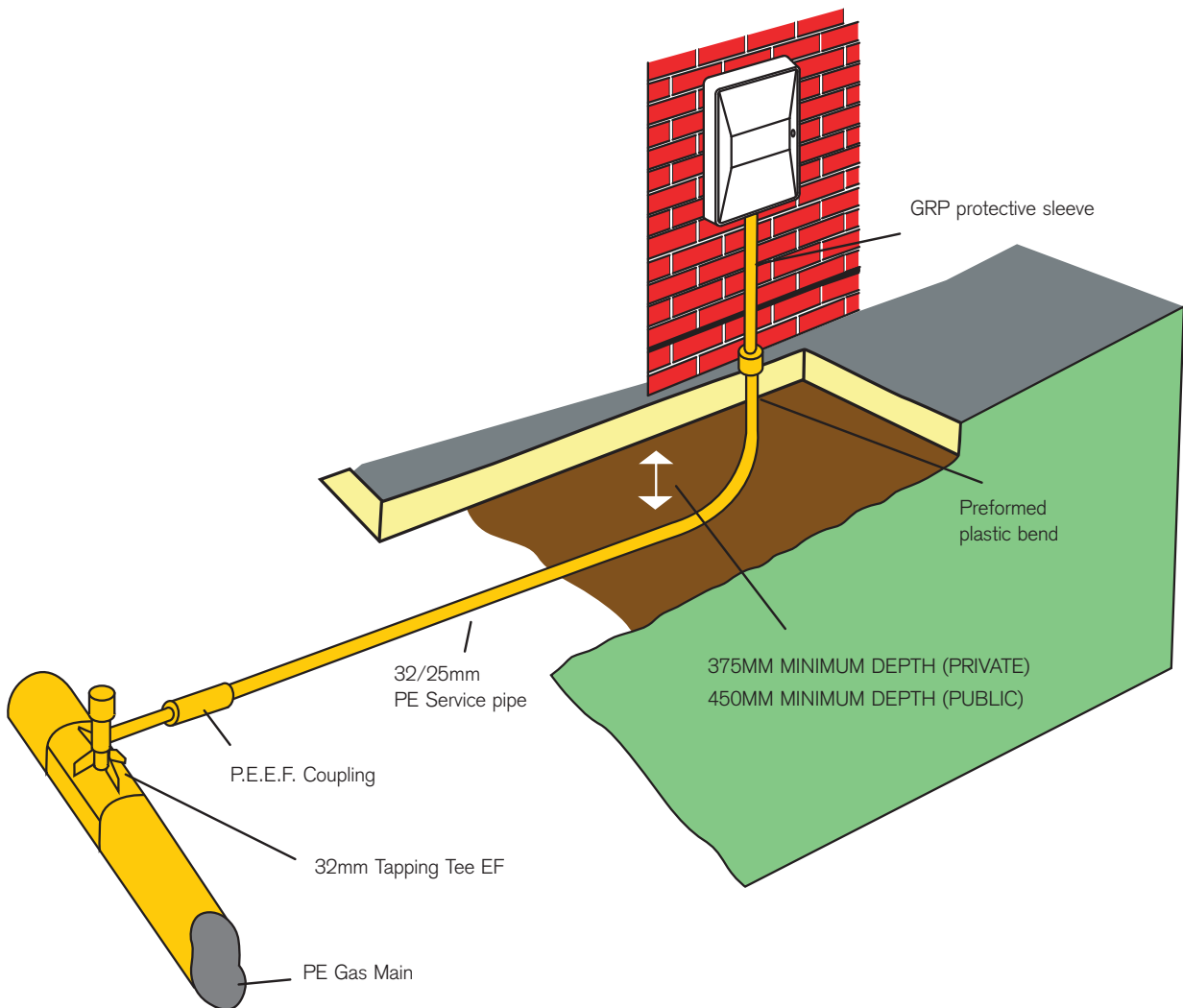

Internal Riser Options

A riser can only be installed in a shaft, duct or void, which has adequate ventilation. If the riser is to be enclosed in a continuous duct or an enclosure, the duct or enclosure must be constructed so that it has at least half an hour fire resistance and naturally ventilated at high and low levels.

Where the duct is not continuous, it should be ventilated at the top and bottom of each isolated section as shown below.

When a riser is installed in a ventilated duct or enclosure, fully removable panels must be provided to allow for access to carry out any future maintenance work.

When risers are not installed in a duct or enclosure, they shall be ventilated indirectly to outside air via an area that is normally occupied and is itself ventilated to outside air, in accordance with Building Regulation requirements.

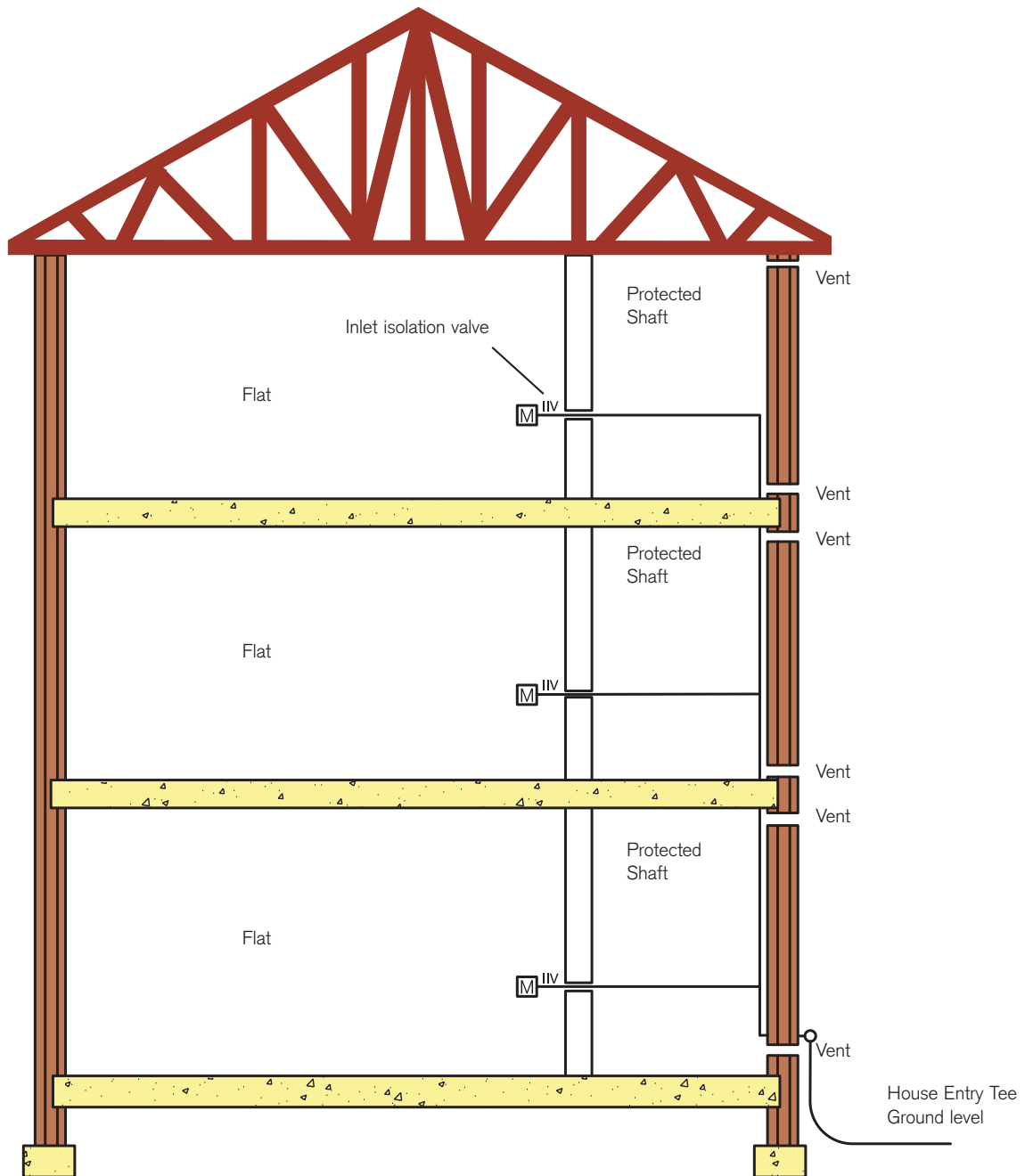

Timber Framed Flats

External risers are not permitted on multi-storey timber framed buildings.

Internal risers and laterals must be designed to accommodate relative movement. The inner leaf wall can shrink with respect to the outer leaf by as much as 12.5mm per floor.

The maximum number of timber frame floors or levels accepted by Manx Gas is one. A higher number of levels are only permissible when the lower levels are of conventional solid construction.

To accommodate the relative timber movement, cored holes for the lateral sleeves have to be oversized to ensure that no excessive stress is applied to the sleeve during the "shrinkage" process.

The diagram below shows the type of flanged sleeve that will be installed by Manx Gas to prevent any possibility of gas entering the cavity.

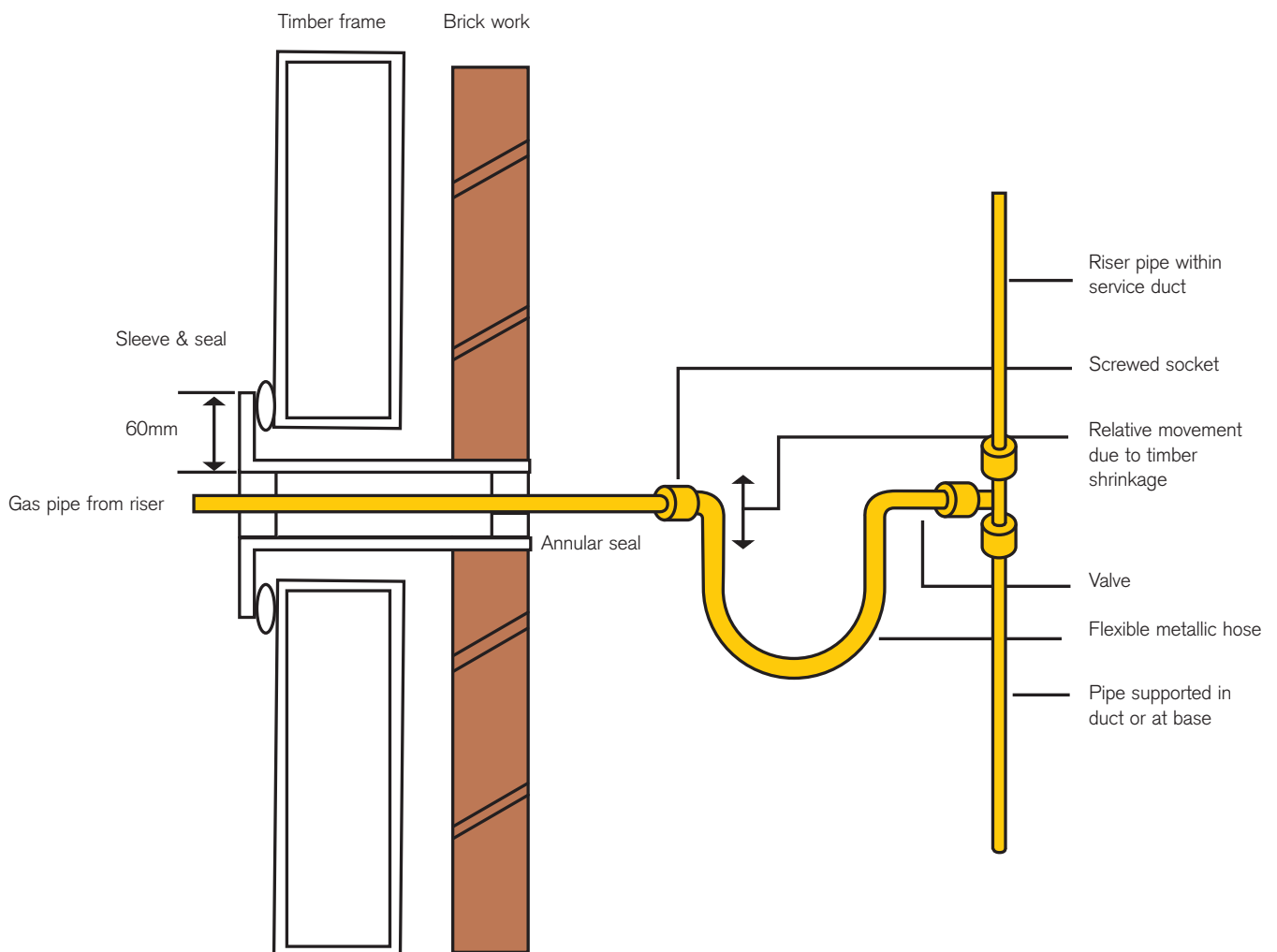

9. Installing Gas Meters

Gas meters can only be installed or moved by an approved meter installer on the instructions of Manx Gas.

Domestic

Meters will be installed in substantially completed properties normally within 5 working days of a request or if requested at the same time that the service is laid.

It is preferred that a minimum of three meters are booked and connected on each visit.

Meters will not be installed in damaged, un-secured or incorrectly located boxes.

Non-Domestic

To arrange for the meter to be installed the developer should contact Manx Gas.

The meter will then be fitted after the Manx Gas installer has checked and confirmed that the ventilation requirement for the type of meter housing is adequate.

Electrical Cross Bonding

An electrical cross bonding wire (where required) should be connected to the gas meter outlet in accordance with IEE Regulations. When the bonding wire enters a built-in box from the rear it must pass through the outlet installation pipe spigot and be contained within the seal. The box must not be broken to accommodate the bonding wire.

10. C.D.M Regulations

The Manx Gas Safety Case details how Manx Gas complies with all relevant Health and Safety legislation affecting the design, installation and operation of gas networks.

Manx Gas will act as the “Designer” and “Principal Contractor” for the construction and commissioning of gas networks on new developments.

The gas mains, services and meters that will be installed on the development will remain the property of Manx Gas Limited. Manx Gas will be responsible for the operation and maintenance of the network.

Should you require any further information please contact the Manx Gas Distribution Manager.

Disclaimer

Although the greatest of care has been taken in the compilation and preparation of this brochure, Manx Gas respectfully accepts no responsibility for any errors, omissions or alterations or for any consequences arising from the use, or reliance upon the information in this brochure.



Energy House
Woolpit Business Park
Woolpit
Bury St Edmunds
Suffolk
IP30 9UP

Tel: 01359 240363
Fax: 01359 241902
e-mail: info@gastrans.co.uk

